

THIS DRAWING IS UNPUBLISHED. RELEASED FOR PUBLICATION, 19 .  
 © COPYRIGHT 19 BY AMP INCORPORATED. ALL INTERNATIONAL RIGHTS RESERVED.

LOC	DIST	P	F	REVISIONS				
AF	50			ZONE	LTR	DESCRIPTION	DATE	APPD
					D	REV PER 0L10-0014-96	8/1/96	JR/PD

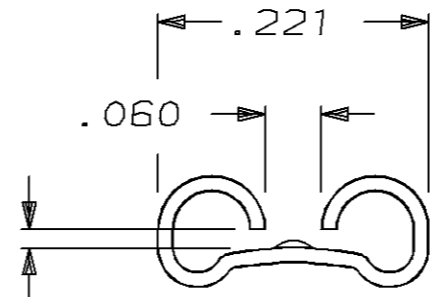
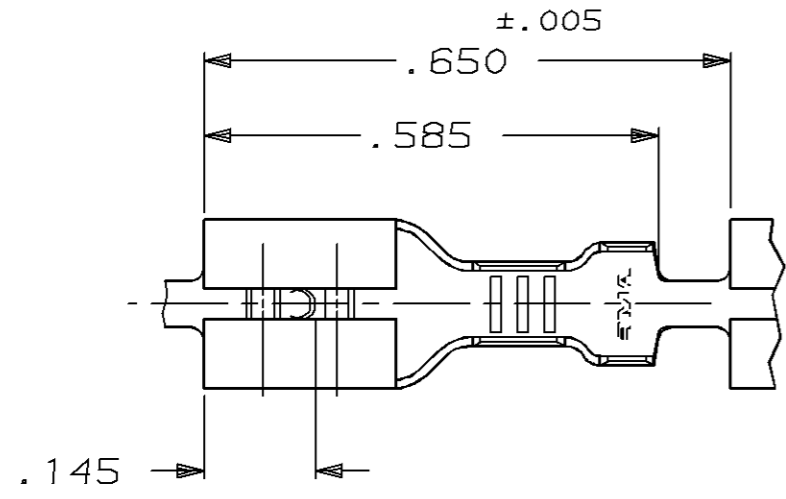

FITS .187 SERIES FASTON TAB

VIEW A-A

1 - CONTINUOUS STRIP ON REELS.

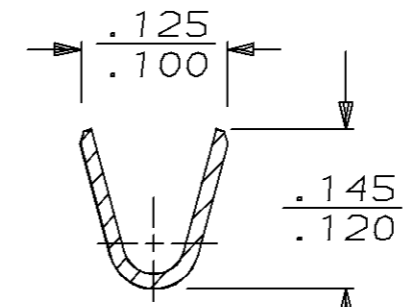
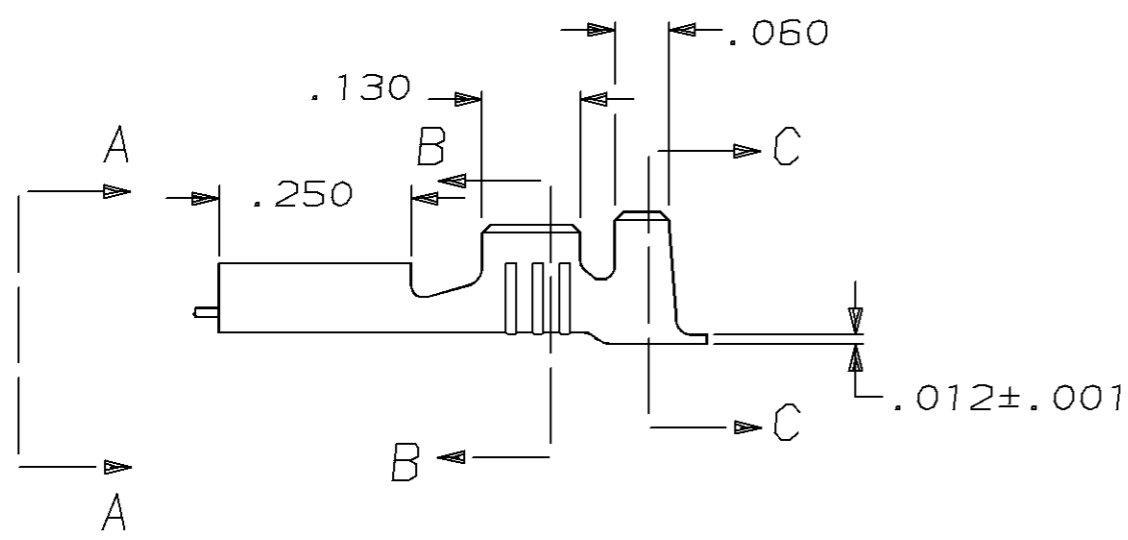

SECTION B-B

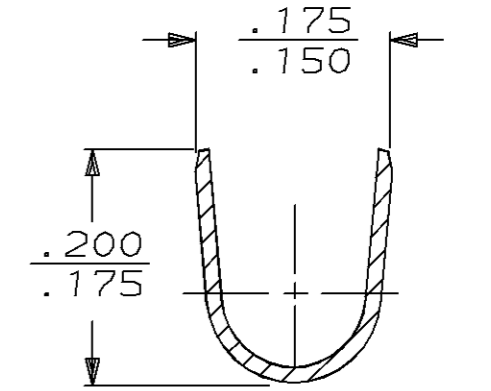

SECTION C-C

THIS DRAWING IS A CONTROLLED DOCUMENT FOR AMP INCORPORATED. IT IS SUBJECT TO CHANGE AND THE CONTROLLING ENGINEERING ORGANIZATION SHOULD BE CONTACTED FOR THE LATEST REVISION.

.090-.130 DIA	#20-#16 AWG	.020±.001	60621-1
INSULATION RANGE	WIRE SIZE	MATING TAB THICKNESS	PART NO
DO NOT SCALE PRINT, UNLESS SPECIFIED. DIMENSIONS IN INCHES. TOLERANCES ON: 2 PLC DEC ± - 3 PLC DEC ± .015 ANGLES ± -	DR 4/3/95 JR RUTH CHK 4/3/95 MS FEHER APPD 4/3/95 P DESANTIS APPD 4/3/95 R REINER PRODUCT SPEC -	<b>AMP</b> AMP Incorporated Harrisburg, PA 17105-3608	
MATERIAL T2 STEEL	FINISH NICKEL	NAME RECEPTACLE, FASTON, .187 SERIES	
	APPLICATION SPEC 114-2036	SIZE B	CAGE CODE 00779
	WEIGHT -	DRAWING NO C=60621	SHEET 1 OF 1
		SCALE 4:1	